

HL Paper 2

This question is about waves.

The diagram represents a standing (stationary) wave in air in a pipe which is open at both ends.

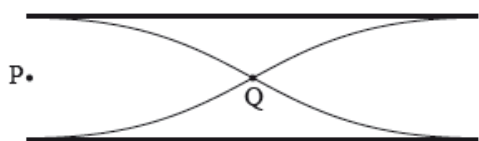

Two points in the pipe are labelled P and Q.

- a. (i) State the direction of oscillation of an air molecule at point P. [3]
- (ii) Compare the amplitude of oscillation of an air molecule at point P with that of an air molecule at point Q.
- b. A hollow pipe open at both ends is suspended just above the ground on a construction site. [2]

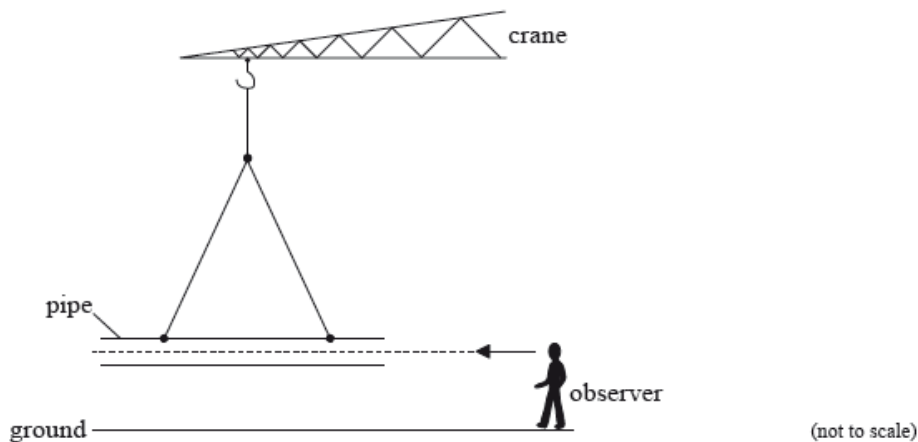

Wind blows across one end of the pipe. This causes a standing wave to form in the air of the pipe, producing the first harmonic. The pipe has a length of 2.1 m and the speed of sound in air is 330 m s^{-1} .

Estimate the frequency of the first harmonic standing wave.

- c. The pipe is held stationary by the crane and an observer runs towards the pipe. Outline how the frequency of the sound measured by the observer is different from the frequency of the sound emitted by the pipe. [3]

This question is in **two** parts. **Part 1** is about a lightning discharge. **Part 2** is about microwave radiation.

Part 2 Microwave radiation

A microwave transmitter emits radiation of a single wavelength towards a metal plate along a line normal to the plate. The radiation is reflected back towards the transmitter.

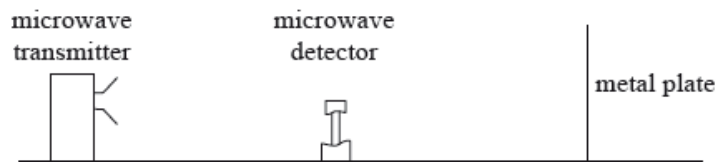

A microwave detector is moved along a line normal to the microwave transmitter and the metal plate. The detector records a sequence of equally spaced maxima and minima of intensity.

The microwave detector is moved through 130 mm from one point of minimum intensity to another point of minimum intensity. On the way it passes through nine points of maximum intensity. Calculate the

Part 2.a. Explain how these maxima and minima are formed. [4]

Part 2.b. i. wavelength of the microwaves. [4]

(ii) frequency of the microwaves.

Part 2.c. Describe and explain how it could be demonstrated that the microwaves are polarized. [3]

This question is about the motion of a ship and observing objects from it.

The sailors on the ship wear polarized sunglasses when observing the sea from the ship. Unpolarized light from the Sun is incident on the sea.

e. A security camera on the ship captures an image of two green lamps on the shore. The lamps emit light of wavelength 520 nm. [3]

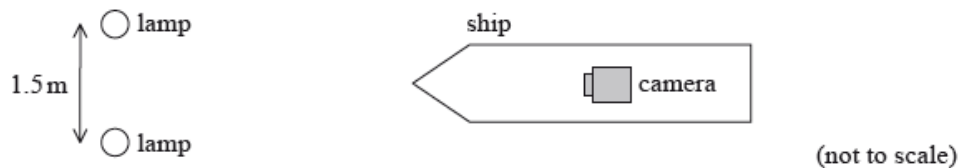

The camera has a circular aperture of diameter 6.2 mm. The lamps are separated by 1.5 m. Determine the maximum distance between the camera and the lamps at which the images of the lamps can be distinguished.

f.i. Describe the polarization of the sunlight that is reflected from the sea. [2]

f.iii. Outline how polarized sunglasses help to reduce glare from the sea. [3]

A beam of coherent monochromatic light from a distant galaxy is used in an optics experiment on Earth.

The beam is incident normally on a double slit. The distance between the slits is 0.300 mm. A screen is at a distance D from the slits. The diffraction angle θ is labelled.

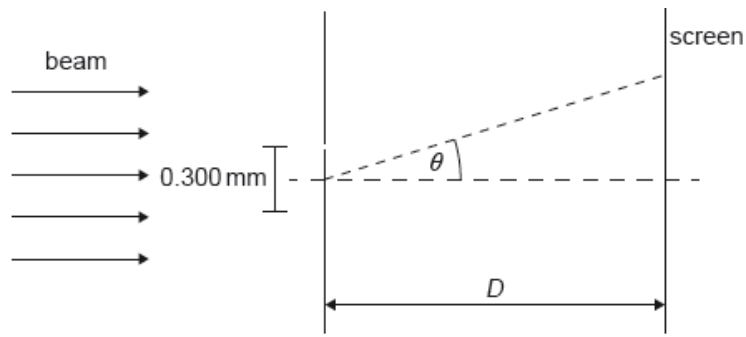

The graph of variation of intensity with diffraction angle for this experiment is shown.

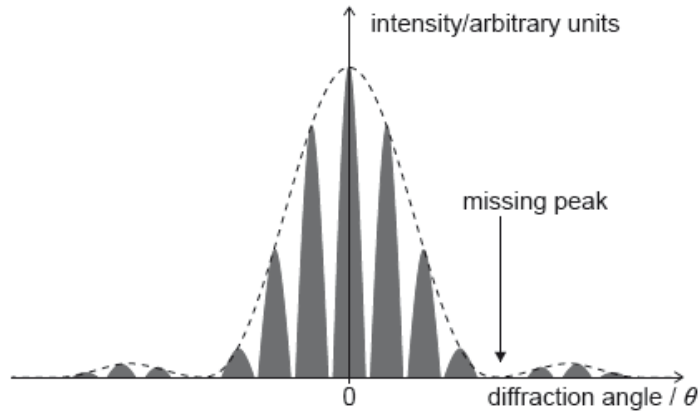

a.ii. Outline why the beam has to be coherent in order for the fringes to be visible. [1]

b.i. Calculate the angular separation between the central peak and the missing peak in the double-slit interference intensity pattern. State your answer to an appropriate number of significant figures. [3]

b.ii. Deduce, in mm, the width of one slit. [2]

c. The wavelength of the light in the beam when emitted by the galaxy was 621.4 nm . [2]

Explain, without further calculation, what can be deduced about the relative motion of the galaxy and the Earth.

The ball is now displaced through a small distance x from the bottom of the bowl and is then released from rest.

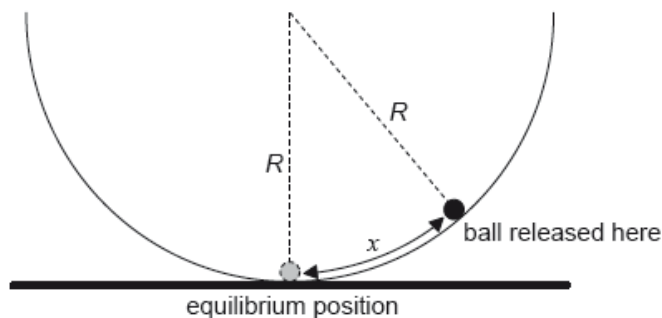

The magnitude of the force on the ball towards the equilibrium position is given by

$$\frac{mgx}{R}$$

where R is the radius of the bowl.

d.i. Outline why the ball will perform simple harmonic oscillations about the equilibrium position.

[1]

d.ii. Show that the period of oscillation of the ball is about 6 s.

[2]

d.iii. The amplitude of oscillation is 0.12 m. On the axes, draw a graph to show the variation with time t of the velocity v of the ball during one period. [3]

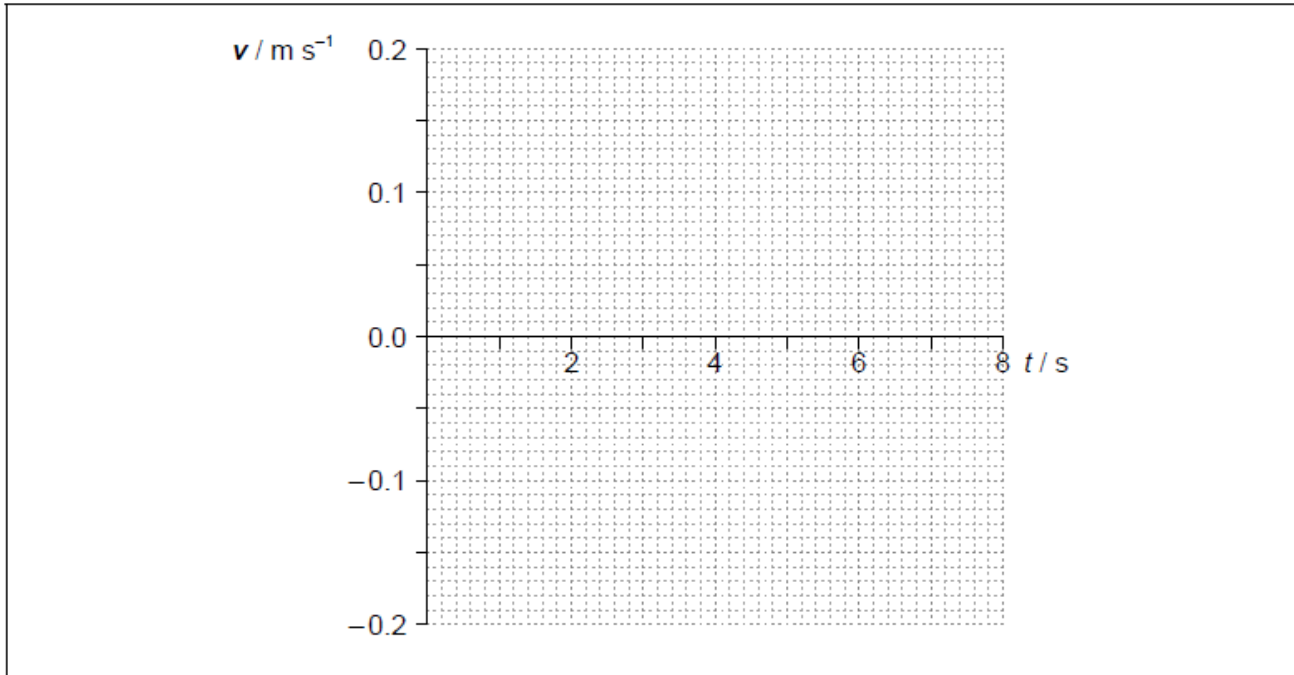

A student is investigating a method to measure the mass of a wooden block by timing the period of its oscillations on a spring.

A 0.52 kg mass performs simple harmonic motion with a period of 0.86 s when attached to the spring. A wooden block attached to the same spring oscillates with a period of 0.74 s.

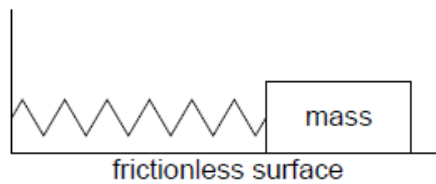

With the block stationary a longitudinal wave is made to travel through the original spring from left to right. The diagram shows the variation with distance x of the displacement y of the coils of the spring at an instant of time.

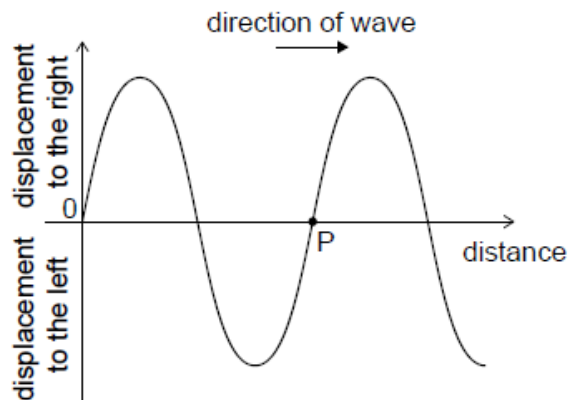

A point on the graph has been labelled that represents a point P on the spring.

- a. Describe the conditions required for an object to perform simple harmonic motion (SHM). [2]
- b. Calculate the mass of the wooden block. [2]
- c. In carrying out the experiment the student displaced the block horizontally by 4.8 cm from the equilibrium position. Determine the total energy in [3] the oscillation of the wooden block.
- d. A second identical spring is placed in parallel and the experiment in (b) is repeated. Suggest how this change affects the fractional uncertainty [3] in the mass of the block.
- e.i. State the direction of motion of P on the spring. [1]
- e.ii. Explain whether P is at the centre of a compression or the centre of a rarefaction. [2]

A buoy, floating in a vertical tube, generates energy from the movement of water waves on the surface of the sea. When the buoy moves up, a cable turns a generator on the sea bed producing power. When the buoy moves down, the cable is wound in by a mechanism in the generator and no power is produced.

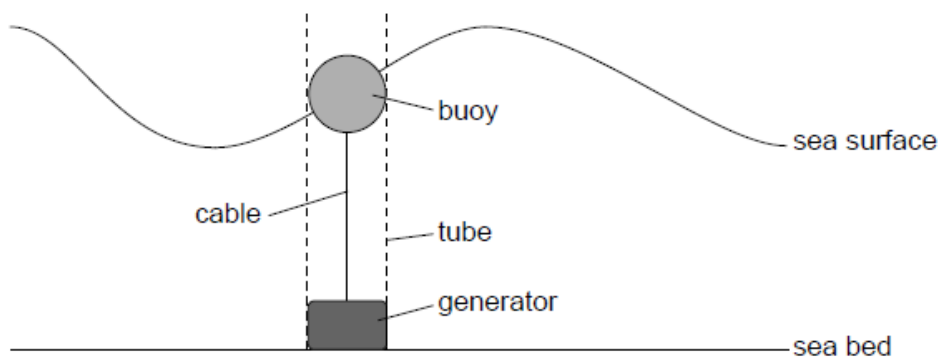

The motion of the buoy can be assumed to be simple harmonic.

Water can be used in other ways to generate energy.

- a. Outline the conditions necessary for simple harmonic motion (SHM) to occur. [2]

b.i. A wave of amplitude 4.3 m and wavelength 35 m, moves with a speed of 3.4 m s^{-1} . Calculate the maximum vertical speed of the buoy. [3]

b.ii. Sketch a graph to show the variation with time of the generator output power. Label the time axis with a suitable scale. [2]

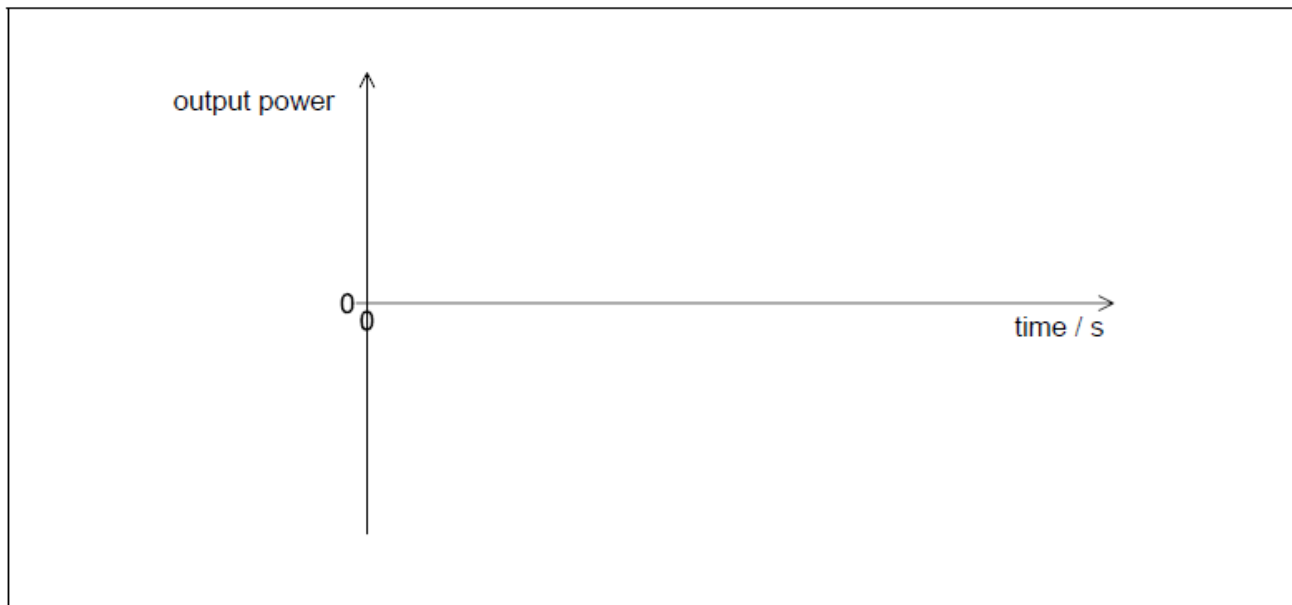

c.i. Outline, with reference to energy changes, the operation of a pumped storage hydroelectric system. [2]

c.ii. The water in a particular pumped storage hydroelectric system falls a vertical distance of 270 m to the turbines. Calculate the speed at which water arrives at the turbines. Assume that there is no energy loss in the system. [2]

c.iii. The hydroelectric system has four 250 MW generators. Determine the maximum time for which the hydroelectric system can maintain full output when a mass of $1.5 \times 10^{10} \text{ kg}$ of water passes through the turbines. [2]

c.iv. Not all the stored energy can be retrieved because of energy losses in the system. Explain **two** such losses. [2]

1.

2.

This question is in **two** parts. **Part 1** is about simple harmonic motion (SHM) and waves. **Part 2** is about atomic and nuclear energy levels.

Part 1 Simple harmonic motion (SHM) and waves

Part 2 Atomic and nuclear energy levels

a. A particle P moves with simple harmonic motion.

[3]

(i) State, with reference to the motion of P, what is meant by simple harmonic motion.

(ii) State the phase difference between the displacement and the velocity of P.

d. The diagram shows four spectral lines in the visible line emission spectrum of atomic hydrogen.

[6]

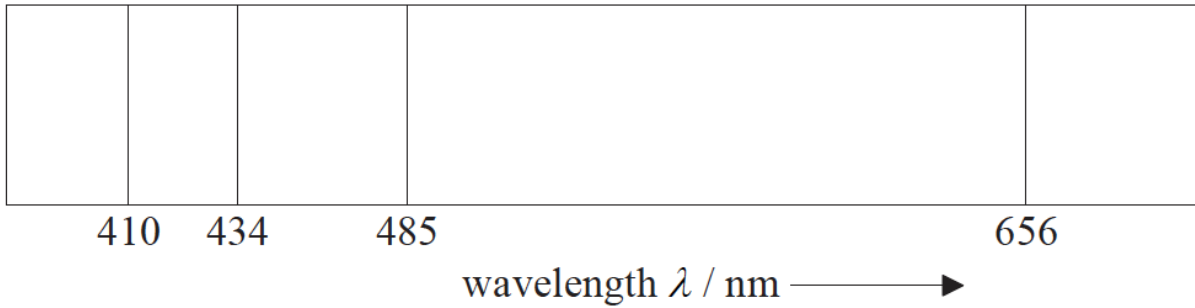

(i) Outline how such a spectrum may be obtained in the laboratory.

(ii) Explain how such spectra give evidence for the existence of discrete atomic energy levels.

e. The energies of the principal energy levels in atomic hydrogen measured in eV are given by the expression

[4]

$$E_n = -\frac{13.6}{n^2} \text{ where } n=1, 2, 3 \dots\dots\dots$$

The visible lines in the spectrum correspond to electron transitions that end at $n=2$.

(i) Calculate the energy of the level corresponding to $n=2$.

(ii) Show that the spectral line of wavelength $\lambda=485\text{nm}$ is the result of an electron transition from $n=4$.

f. The alpha particles and gamma rays produced in radioactive decay have discrete energy spectra. This suggests that nuclei also possess

[2]

discrete energy levels. However, beta particles produced in radioactive decay have continuous energy spectra. Describe how the existence of the antineutrino accounts for the continuous nature of beta spectra.

This question is about the properties of waves.

Microwaves from a microwave transmitter are reflected from two parallel sheets, A and B. Sheet A partially reflects microwave energy while allowing some to pass through. All of the microwave energy incident on sheet B is reflected.

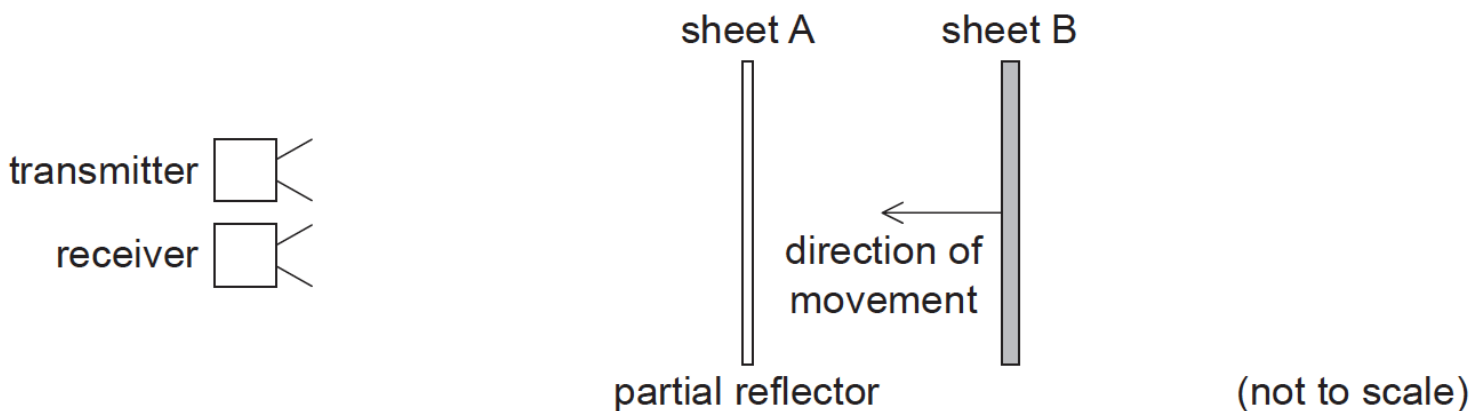

Sheet A is fixed and sheet B is moved towards it. While sheet B is moving, the intensity of the signal detected at the receiver goes through a series of maximum and minimum values.

a. Outline why a minimum in the intensity occurs for certain positions of sheet B. [3]

c. The apparatus is arranged to demonstrate diffraction effects. [3]

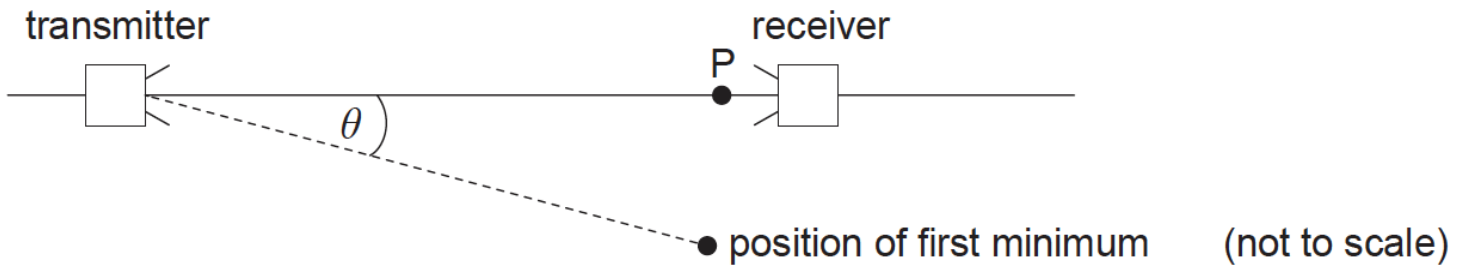

The microwaves emerge from the transmitter through an aperture that acts as a single slit.

(i) Outline what is meant by diffraction.

(ii) A maximum signal strength is observed at P. When the receiver is moved through an angle θ , a first minimum is observed. The width of the aperture of the transmitter is 60 mm. Estimate the value of θ .

d. Microwaves can be used to demonstrate polarization effects. Outline why an ultrasound receiver and transmitter **cannot** be used to demonstrate polarization. [2]

This question is about polarization.

a. State what is meant by polarized light. [1]

b. Unpolarized light is incident on the surface of a plastic. The angle of incidence is θ . The reflected light is viewed through an analyser whose transmission axis is vertical. [2]

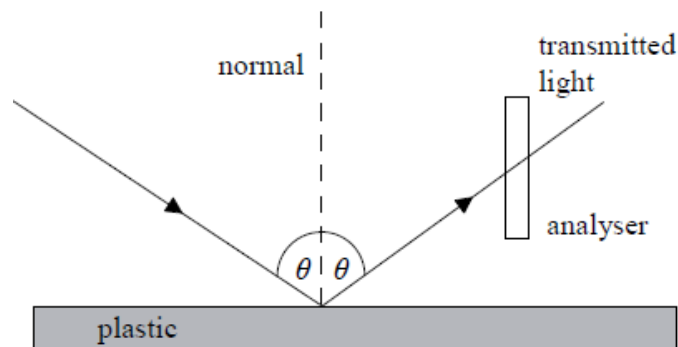

The variation with θ of the intensity I of the transmitted light is shown in the graph.

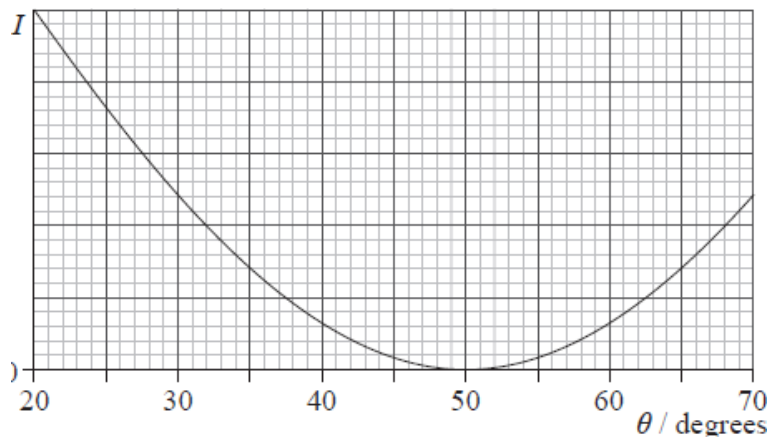

Explain why there is an angle of incidence, for which the intensity of the transmitted light is zero.

- c. Unpolarized light from a source is split, so that there is a path difference of half a wavelength between the two beams. [4]

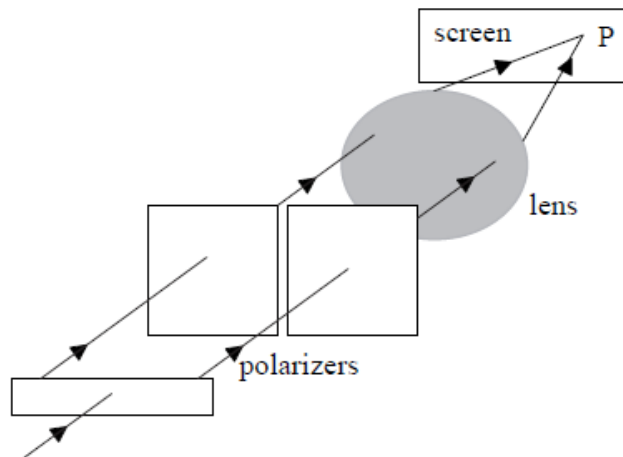

A lens brings the light to focus at point P on a screen. The lens does not introduce any additional path difference.

State and explain whether any light would be observed at P, in the case in which the polarizers have their transmission axes

- (i) parallel.
- (ii) at right angles to each other.

This question is about sound.

A source emits sound of frequency f . The source is moving towards a stationary observer at constant speed. The observer measures the frequency of the sound to be f' .

- a. (i) Explain, using a diagram, why f' is greater than f . [5]

(ii) The frequency f is 275 Hz. The source is moving at speed 20.0 ms^{-1} . The speed of sound in air is 330 ms^{-1} . Calculate the observed frequency f' of the sound.

- b. A source of sound is placed in front of a barrier that has an opening of width comparable to the wavelength of the sound. [4]

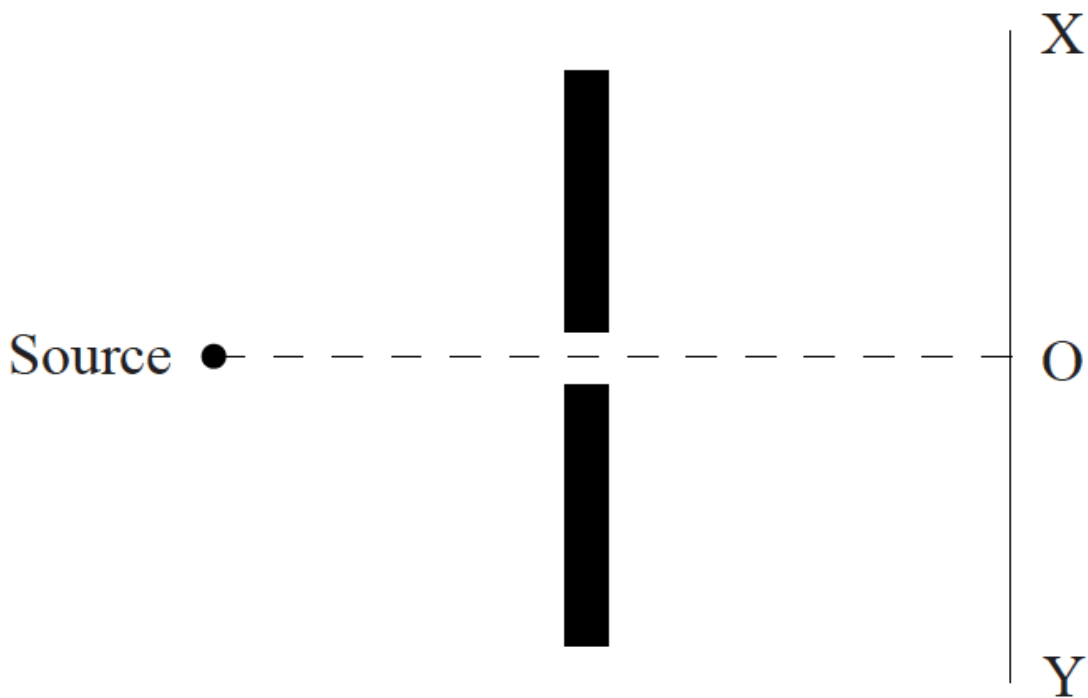

A sound detector is moved along the line XY. The centre of XY is marked O.

(i) On the axes below, sketch a graph to show how the intensity I of the sound varies as the detector moves from X to Y.

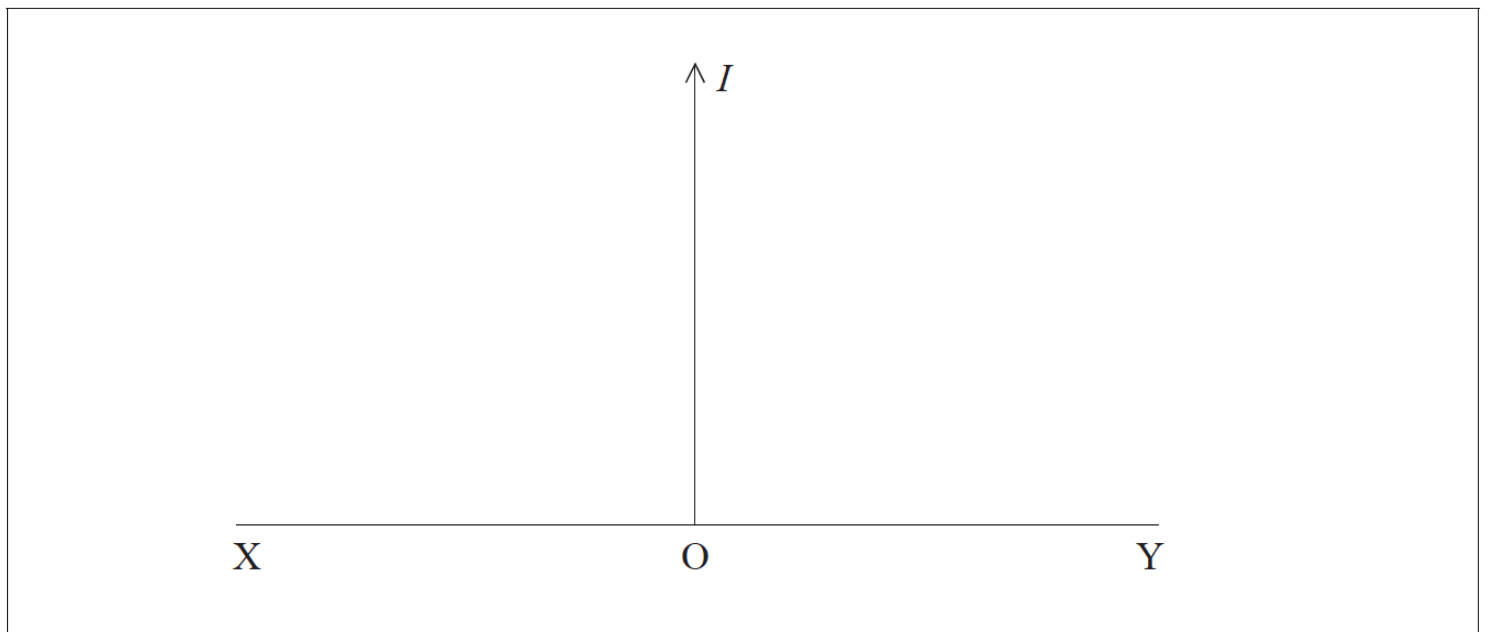

(ii) State the effect on the intensity pattern of increasing the wavelength of the sound.

c. (i) Outline the difference between a polarized wave and an unpolarized wave.

[3]

(ii) State why sound waves cannot be polarized.

A longitudinal wave is travelling in a medium from left to right. The graph shows the variation with distance x of the displacement y of the particles in the medium. The solid line and the dotted line show the displacement at $t=0$ and $t=0.882$ ms, respectively.

y / mm

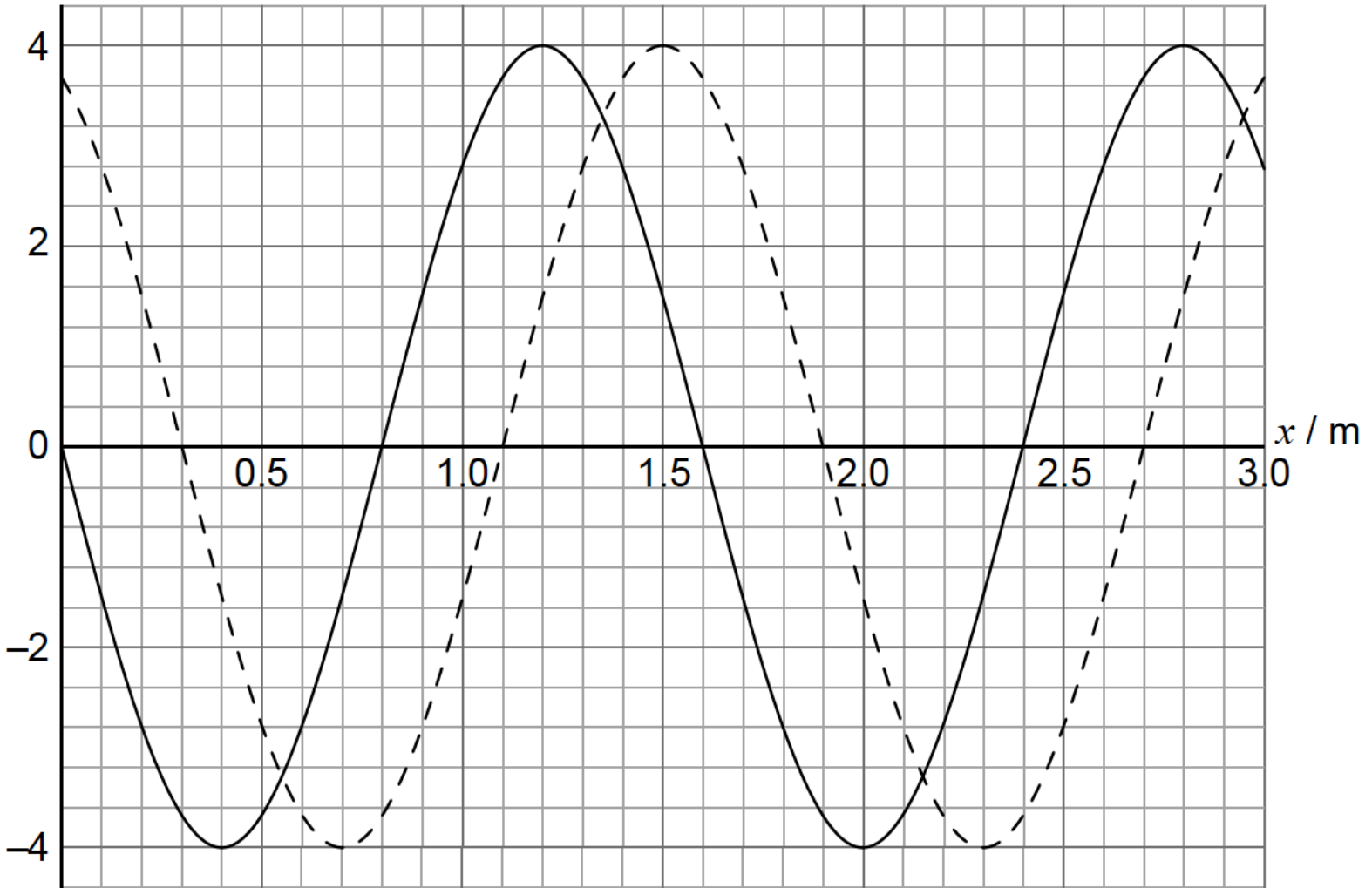

The period of the wave is greater than 0.882 ms. A displacement to the right of the equilibrium position is positive.

b. (i) Calculate the speed of this wave.

[4]

(ii) Show that the angular frequency of oscillations of a particle in the medium is $\omega = 1.3 \times 10^3 \text{ rad s}^{-1}$.

c. One particle in the medium has its equilibrium position at $x = 1.00 \text{ m}$.

[4]

(i) State and explain the direction of motion for this particle at $t = 0$.

(ii) Show that the speed of this particle at $t = 0.882 \text{ ms}$ is 4.9 ms^{-1} .

d. The travelling wave in (b) is directed at the open end of a tube of length 1.20 m. The other end of the tube is closed.

[3]

(i) Describe how a standing wave is formed.

(ii) Demonstrate, using a calculation, that a standing wave will be established in this tube.

Monochromatic light is incident normally on four thin, parallel, rectangular slits.

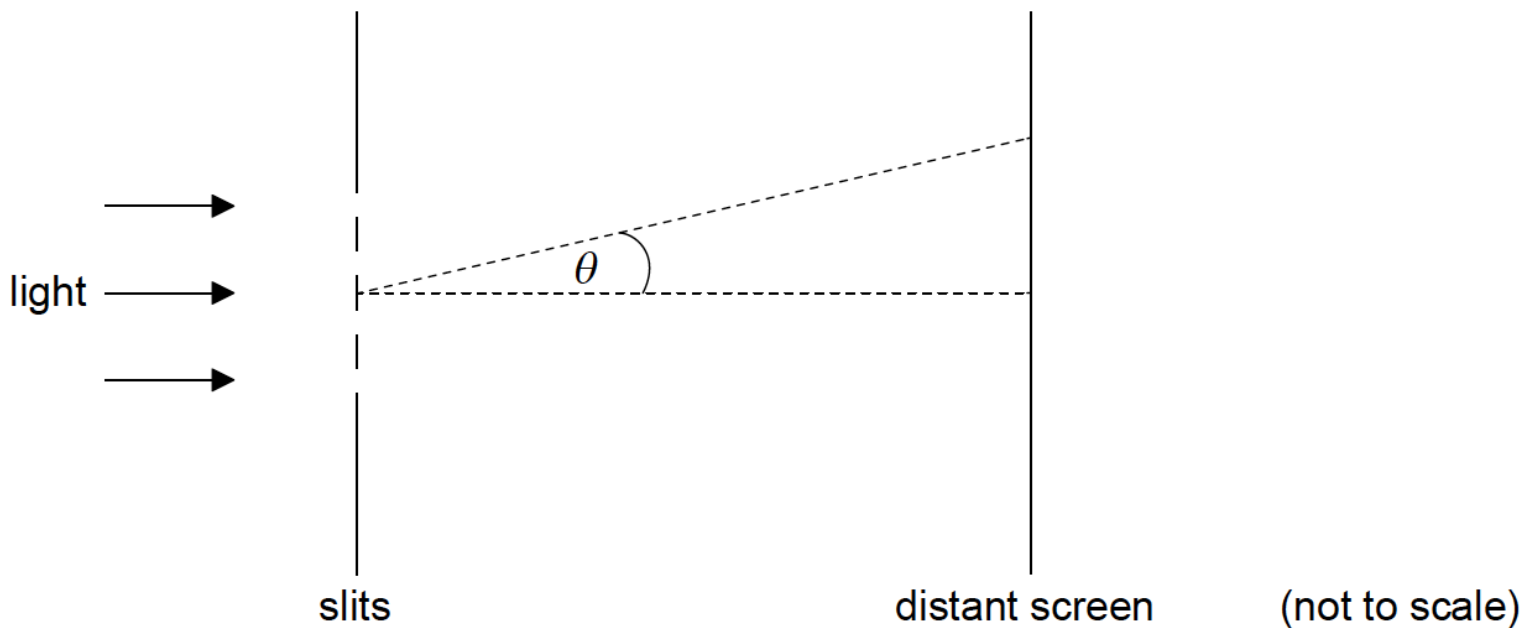

The graph shows the variation with diffraction angle θ of the intensity of light I at a distant screen.

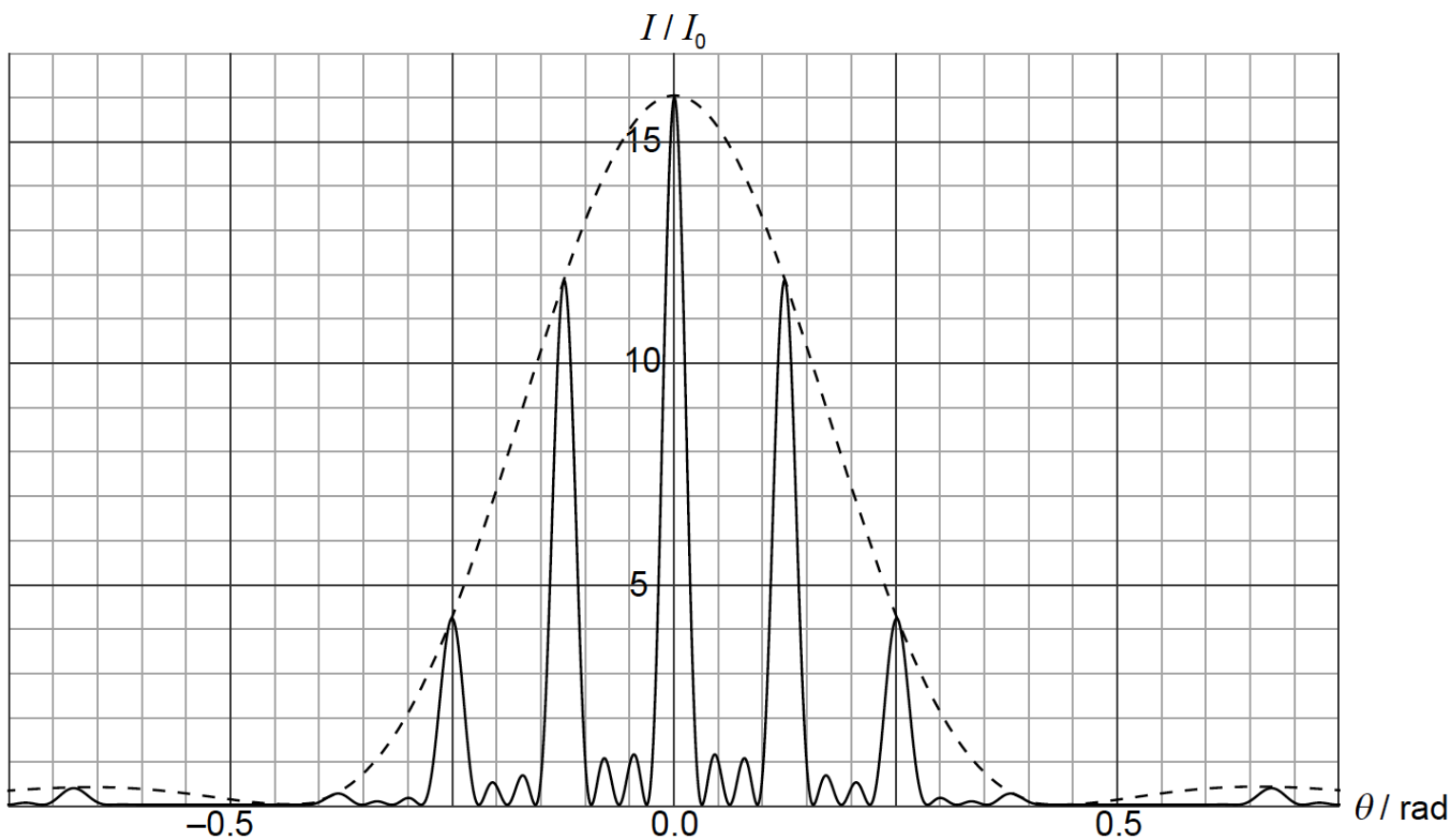

I_0 is the intensity of the light at the middle of the screen from **one** slit.

a. Explain why the intensity of light at $\theta=0$ is $16I_0$. [3]

b. The width of each slit is $1.0\mu\text{m}$. Use the graph to [4]

(i) estimate the wavelength of light.

(ii) determine the separation of **two** consecutive slits.

c. The arrangement is modified so that the number of slits becomes very large. Their separation and width stay the same.

[4]

(i) State **two** changes to the graph on page 20 as a result of these modifications.

(ii) A diffraction grating is used to resolve two lines in the spectrum of sodium in the second order. The two lines have wavelengths 588.995nm and 589.592nm.

Determine the minimum number of slits in the grating that will enable the two lines to be resolved.

A student investigates how light can be used to measure the speed of a toy train.

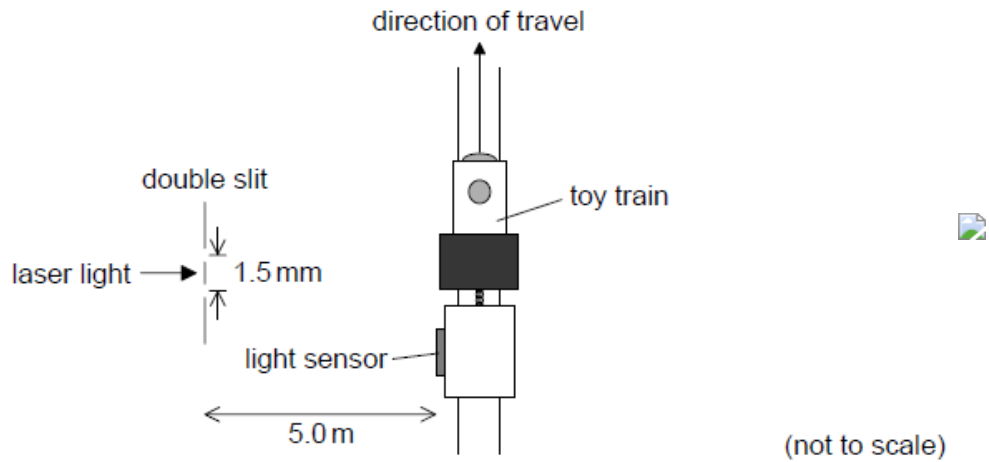

Light from a laser is incident on a double slit. The light from the slits is detected by a light sensor attached to the train.

The graph shows the variation with time of the output voltage from the light sensor as the train moves parallel to the slits. The output voltage is proportional to the intensity of light incident on the sensor.

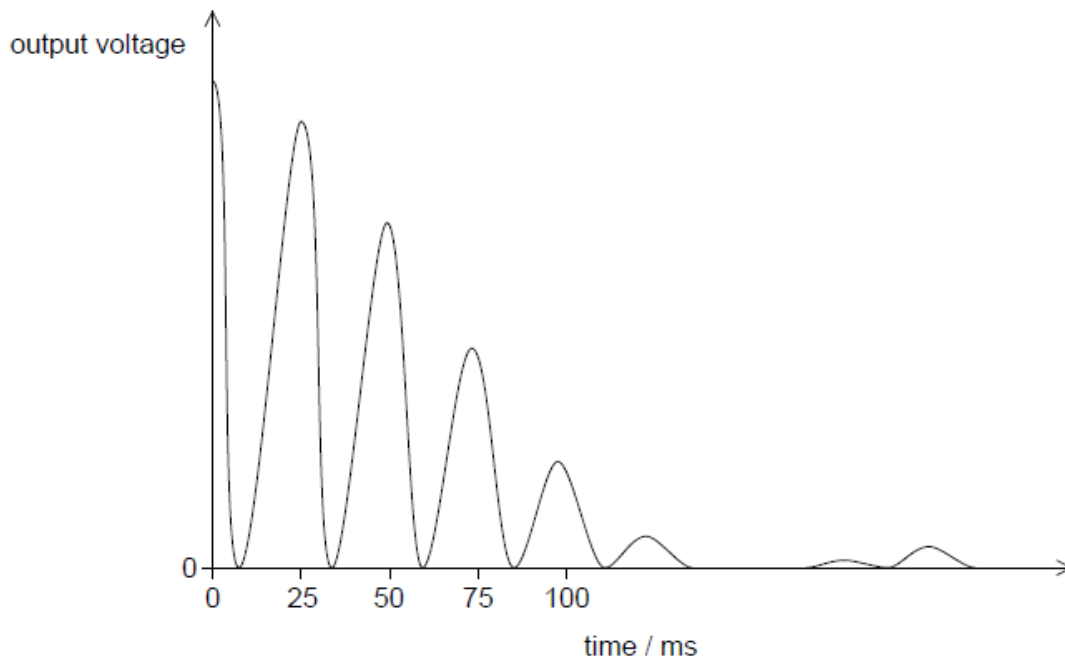

As the train continues to move, the first diffraction minimum is observed when the light sensor is at a distance of 0.13 m from the centre of the fringe pattern.

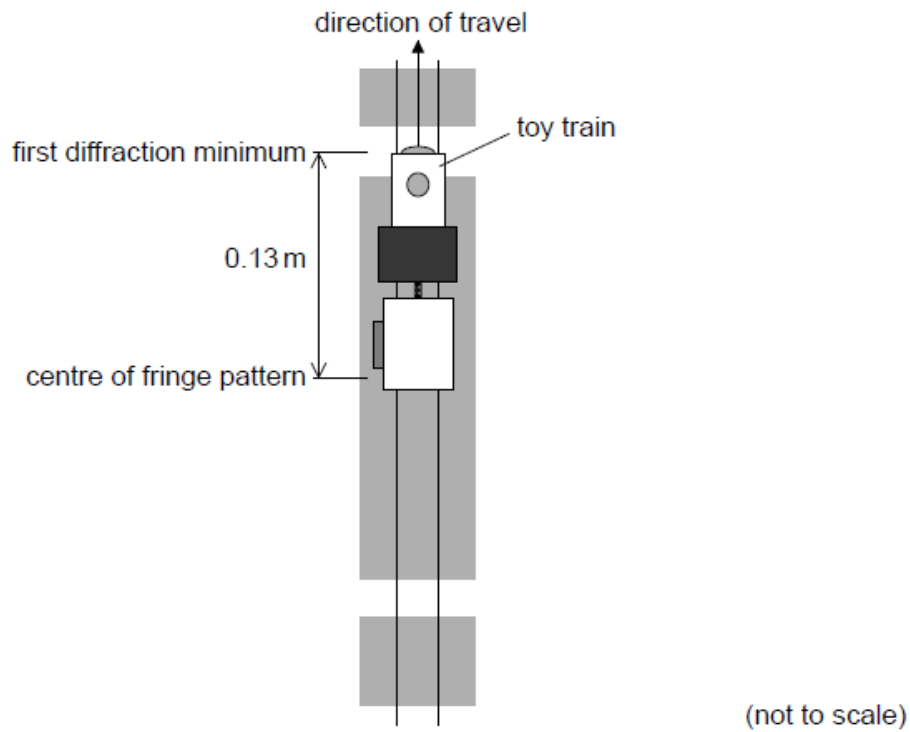

c.i. Determine the width of one of the slits. [2]

c.ii. Suggest the variation in the output voltage from the light sensor that will be observed as the train moves beyond the first diffraction minimum. [2]

d. In another experiment the student replaces the light sensor with a sound sensor. The train travels away from a loudspeaker that is emitting sound waves of constant amplitude and frequency towards a reflecting barrier. [2]

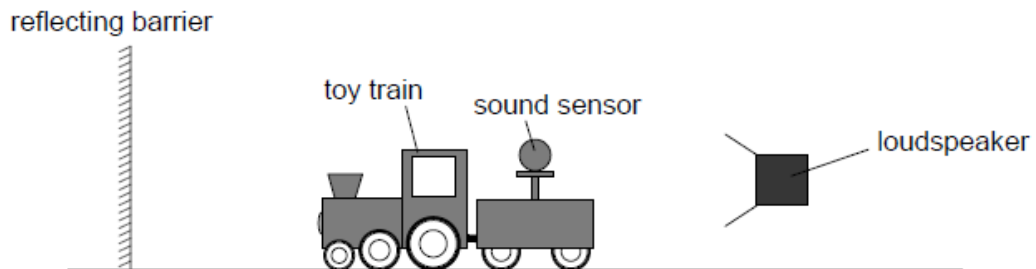

The graph shows the variation with time of the output voltage from the sounds sensor.

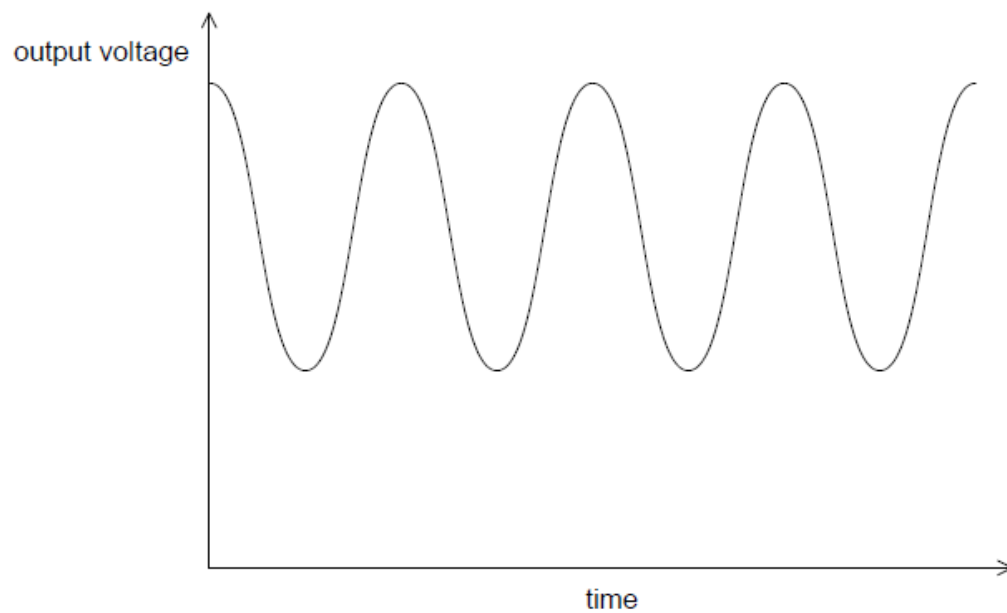

Explain how this effect arises.

This question is about polarization.

Unpolarized light is directed towards two polarizers. The dashed lines represent the transmission axes of the polarizers. The angle θ between the transmission axes of the polarizers is initially 0° .

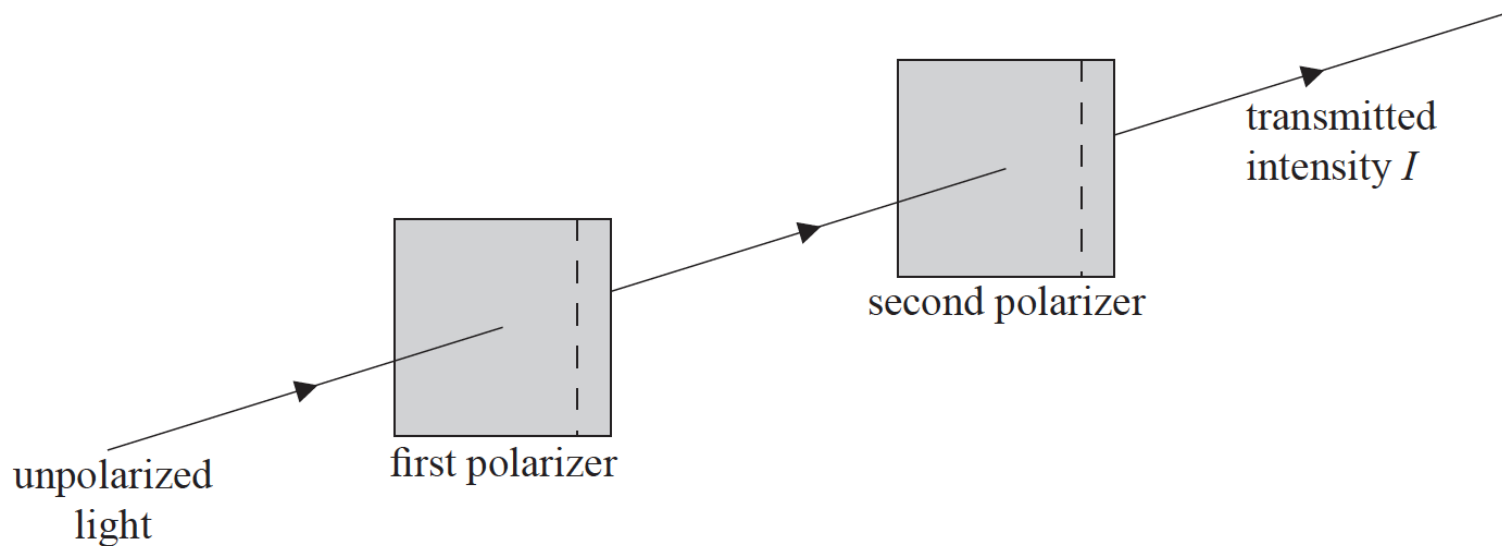

On the axes below, sketch a graph to show how the intensity I of the light emerging from the second polarizer varies with θ .

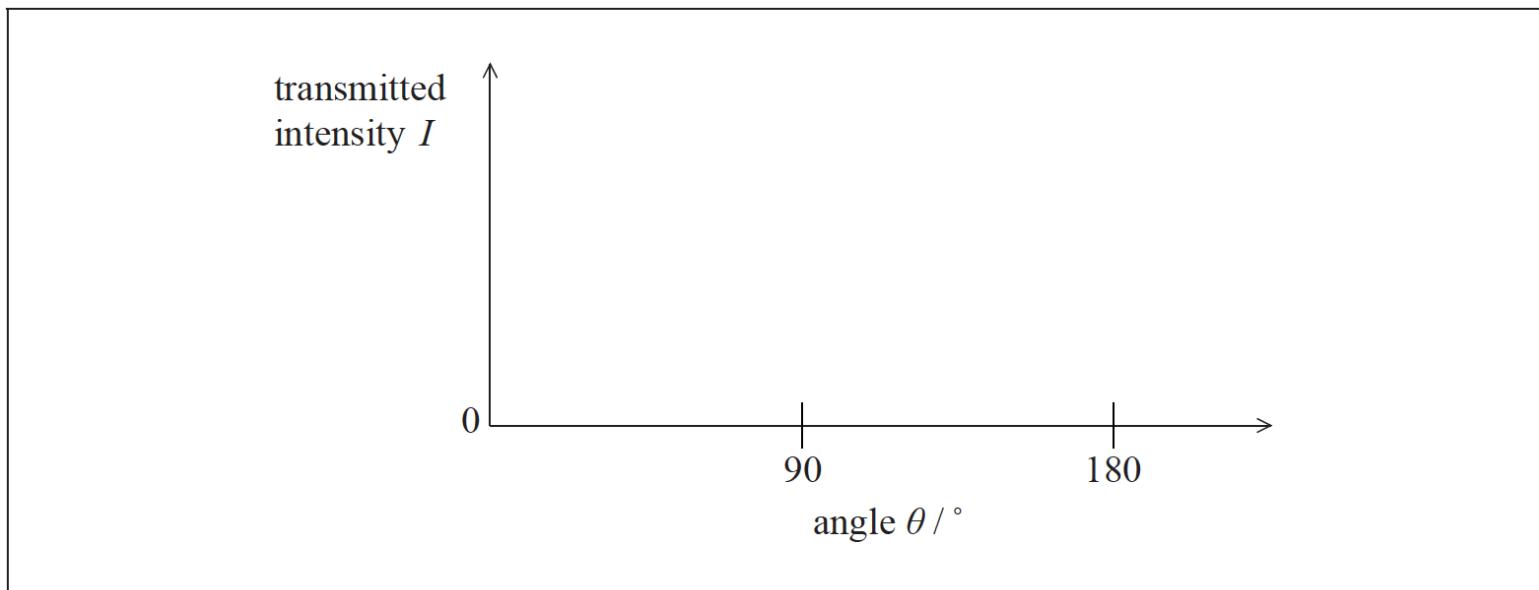

This question is about simple harmonic motion (SHM), wave motion and polarization.

b. A liquid is contained in a U-tube.

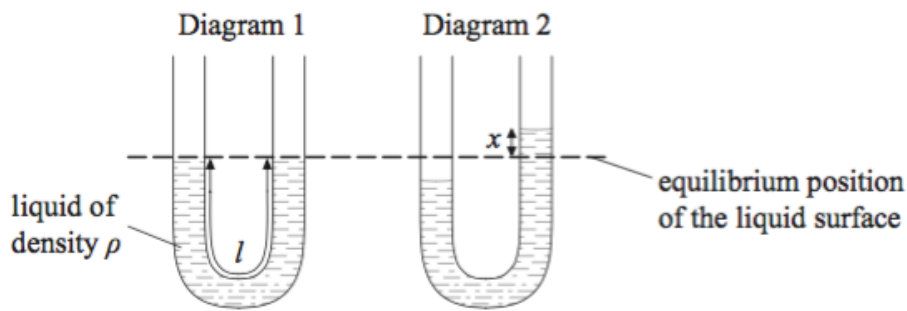

The pressure on the liquid in one side of the tube is increased so that the liquid is displaced as shown in diagram 2. When the pressure is suddenly released the liquid oscillates. The damping of the oscillations is small.

- (i) Describe what is meant by damping.
- (ii) The displacement of the liquid surface from its equilibrium position is x . The acceleration a of the liquid in the tube is given by the expression

$$a = -\frac{2g}{l}x$$

where g is the acceleration of free fall and l is the total length of the liquid column. Explain, with reference to the motion of the liquid, the significance of the minus sign.

- (iii) The total length of the liquid column in the tube is 0.32m. Determine the period of oscillation.

d. The string in (c) is fixed at both ends and is made to vibrate in a vertical plane in its first harmonic.

[6]

- (i) Describe how the standing wave in the string gives rise to the first harmonic.
- (ii) Outline how a travelling wave in a string can be used to describe the nature of polarized light.